

Keeping Safe from Burglaries and Robberies!

Safes

Hiding a safe just gives a burglar better working conditions.

Try to:

- Position the safe so it's visible from the outside.
- Keep the safe area well lit.
- Anchor the safe so it can't be moved.
- Don't leave the combination where unauthorized persons may find it.
- Change combinations when you change employees that have access to the safe.
- Frequently bank all excess cash.
- Install a perimeter alarm with local or central station connection. Routinely check its working condition.

Doors

- Install bars, and lock in place, on rear or side doors.
- To discourage drilling or sawing, install metal linings on the inside of rear and side wooden doors.
- Weld exterior door hinge pins in place.
- Install grates over windows where maximum security is needed.

Locks

- If unsure of your exterior door locks, have them examined by a qualified locksmith.
- Keep an up-to-date record of the keys you issue.
- Stamp keys "Do Not Duplicate."
- Replace hasps and padlocks with modern, double cylinder-type, deadbolt locks where permitted by law. Check with fire or building code officials.
- Retrieve all keys from terminating employees.
- Use a code for key identification purposes.
- Take periodic key inventories.

Alarms

Central station burglar alarms, installed and serviced by a reputable firm are a major burglary deterrent. Where "smash and grab" potentials exists, it may also be necessary to use removable or sliding metal grates over windows and doors.

Lights

Burglars tend to avoid well-lit areas.

- Light all entrances, passageways, and building sides.
- Leave some inside lights on so police can see in.
- Keep display windows cleared enough for police to see through.

1 Protect access to roof.

2 Install store-wide alarm system.

3 Keep safe in lighted, visible area.

4 Install modern, adequate locks.

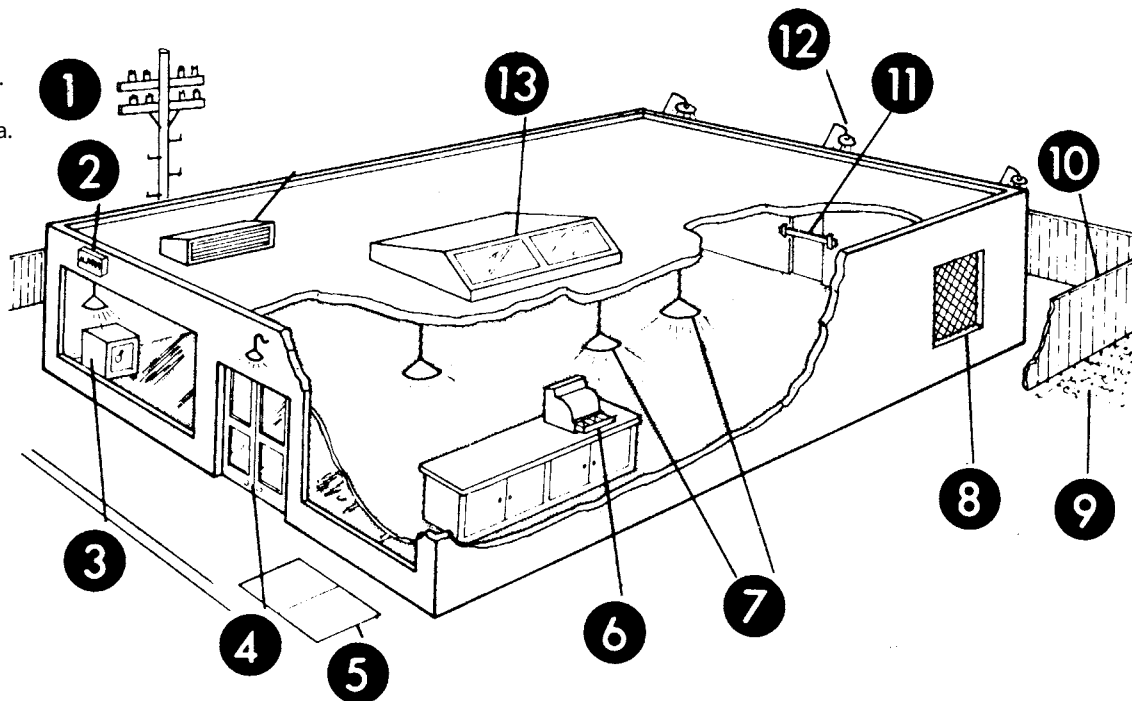

5 Secure all openings.

6 Keep empty cash drawer open to prevent damage.

7 Adequate lighting inside.

8 Lock and bar windows.

9 Clear away debris.

10 Keep fences in good repair.

11 Lock and bar doors.

12 Install outside lights behind building and in alleyways.

13 Secure all roof openings.

Other Tips

- If you don't use an armored car service, vary deposit times and routes taken to the bank.
- Establish an opening/closing routine involving two people; one inside checking locks, alarms, and for unwanted callers; one outside observing until an "all safe" signal is given.
- Make sure your assistant knows the nearest phone locations and carries a card with police number and correct change taped on it.
- When responding to an emergency night call, notify someone that you're returning to the business.
 - If it's a burglar alarm, ask for a police car to meet you.
 - If it's a repair problem, send for the service truck before you leave.
 - Upon arrival and no police car or repair truck is present, don't park near the business and don't enter it.
 - Verify all phone calls you receive after hours, no matter when they originate.
- At night, leave the cash register open and empty to prevent damage.
- Train employees on how to act in case of robbery. Emphasize the protection of lives. Make it clear no "heroes" are wanted. When facing a robber: Stay as calm as possible. Reassure the robber he has complete cooperation. Do as you're told. Make mental notes on the criminal's build, voice, complexion, haircolor, clothing, or any distinguishing marks. Give police full cooperation.
- In case of burglary: Telephone the police immediately. Avoid all movement in the area of entry and theft. Instruct your employees/co-workers to leave the scene completely undisturbed. Assist officers by providing information about any missing items.
- Many police departments have crime prevention units that survey businesses and offer security suggestions. They welcome inquiries.

This publication is advisory only. The safety of your premises and persons to whom you owe a duty of care remains your primary responsibility. Unigard does not warrant that compliance with this advisory will result in an accident free operation or legal compliance with federal, state, or local laws, regulations, or standards.

Unigard® is a registered service mark of Unigard Insurance Company of Bellevue, Washington.

Unigard Insurance Group

Corporate Headquarters, P.O. Box 90701, Bellevue, WA

- Unigard Insurance Company
- Unigard Indemnity Company

Keeping **Safe** from Burglaries

Give your business a checkup. Simple precautions can reduce the chances of burglary or robbery.

Information from
Unigard®

